



**SPECIFICATION SHEET**



reddot award 2015 winner

**AVENTOS HK-XS** - small stay lift wall cabinet

- Suitable for tall wall cabinets
- Combine with CLIP top BLUMOTION hinges for silent and effortless closing
- Combine with TIP-ON mechanical opening support system for handle-less solution
- Lift door can stop and remain in any positions with infinitely variable lift mechanism adjustment
- Lift mechanism can be used one or both sides of the cabinet

- Country of origin:** Austria
- Motion technologies:** BLUMOTION TIP-ON
- Material / Finish:** Steel / Zinc plated
- Cabinet width:** depends on power factor
- Cabinet height:** 240 - 600 mm
- Internal minimum depth:** 125 mm

**Space requirement**

For BLUMOTION

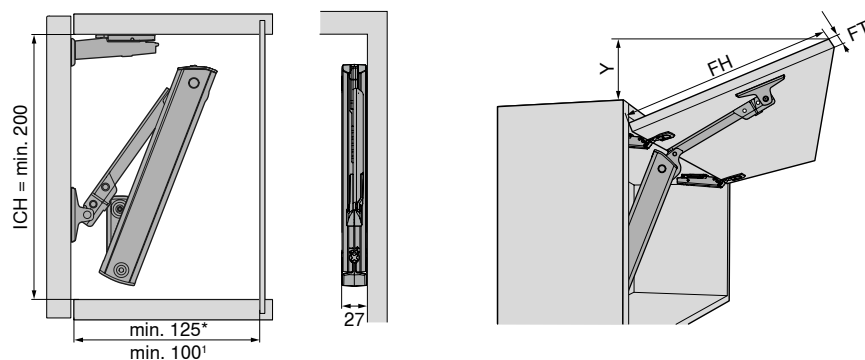

**CLIP top BLUMOTION 110° hinge**

FT	16	19	22	24
X	45	34	23	15

$Y = (FH - X) \times 0.3$

For cornice / crown

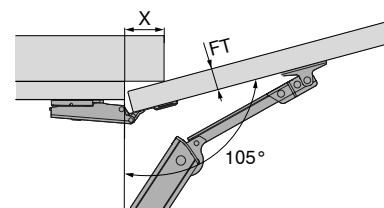

**CLIP top BLUMOTION 110° hinge**

FT	16	19	22	24
X	45	34	23	15

All measurements are in millimetres (mm)

\* Min. 200 with visible wall hanging bracket

<sup>1</sup> Internal cabinet depth 100 mm

ICH Internal cabinet height

FH Front height  
FT Front thickness



**SPECIFICATION SHEET**



reddot award 2015  
winner

**AVENTOS HK-XS** - small stay lift wall cabinet

**Power factor (PF)**



**Power factor (PF) = cabinet door height in mm x (cabinet door weight in kg + double handle weight in kg)**

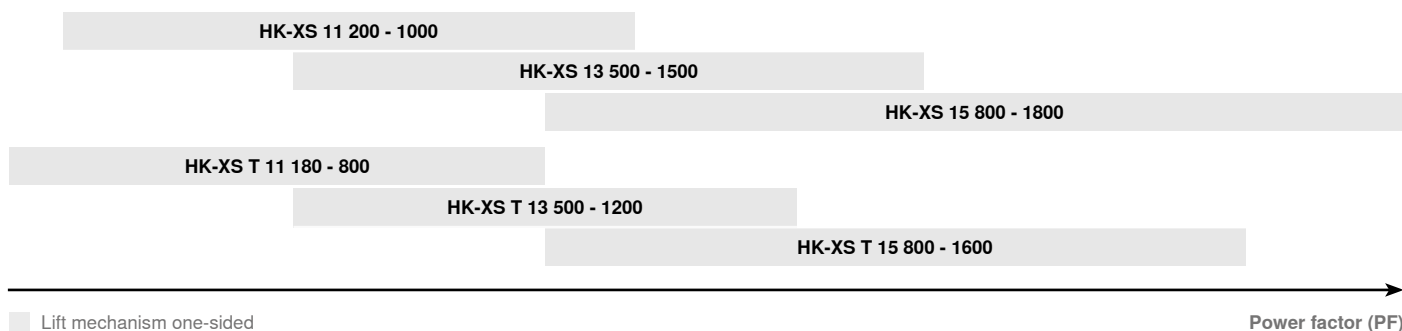

All content is copyrighted by Blum. Subject to modifications and changes without notice. Produced in Singapore. PQR FL Ss · AVN HK-XS · V1 EN-SG