



TANDEM runner - single extension

- For wooden drawers with panel thickness measuring 11 - 16 mm
- Integrated with built-in width and depth tolerance compensation
- Low-friction cylindrical nylon rollers ensure a feather-light glide
- Easy opening and integrated with BLUMOTION for silent and effortless closing
- Compatible with SERVO-DRIVE electrical opening support system*
- Tool-free height adjustment via locking device (with T51.1700.04)

Country of origin:	Austria
Motion technologies:	 BLUMOTION  SERVO-DRIVE*
Material / Finish:	Steel / Zinc plated
Cabinet width:	300 - 1200 mm
Nominal length:	270, 300, 350, 400, 450, 500, 550 mm
Load bearing capacity:	30 kg

*SERVO-DRIVE set and transformer set sold separately

Space requirement

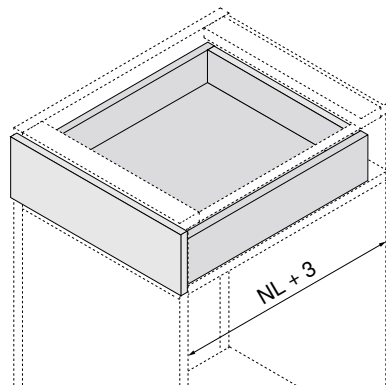

All measurements are in millimetres (mm)

NL Nominal length